

# Roll into productivity

Castors & Wheels For All Industries

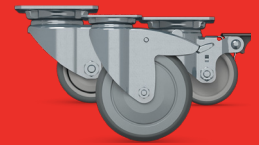



### Understanding the families

Each family has its own set of standards that distinguish them from other product families. These standards may focus on aspects such as high load capacity, specific design requirements, or unique areas of application.

Each individual model within the product family has a system of design variables that are tailored to its specific characteristics, including dimensioning, technical requirements, and necessary configuration.

### Making the right choice

Our guide makes the task of selecting the correct castor simple. On the following pages, we go into further detail of the range of families we offer.

This section highlights some of the most important features and the industry where the product is most commonly used. To view full details of the family simply scan the QR code at the bottom of each page or visit...

[jetpress.com](http://jetpress.com)

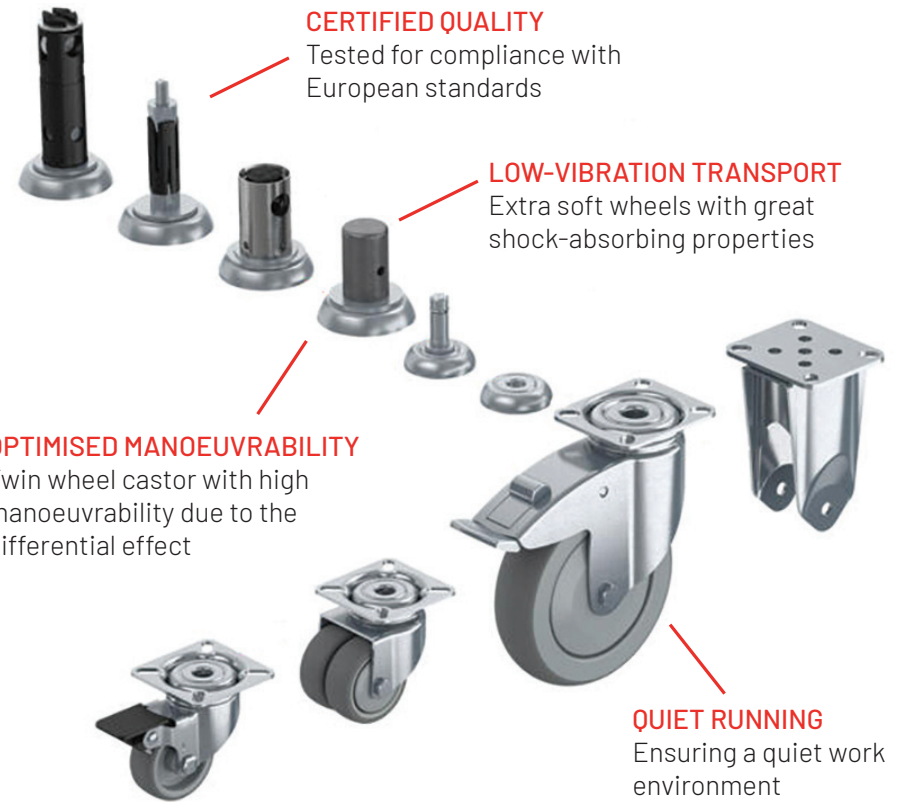
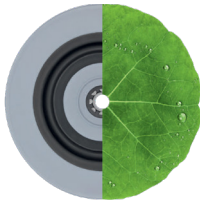

Typically used in...



**RETAIL & TRADE**

To view the full details on the Agila family scan the QR



# Basetech

Polypropylene Wheels



**ECO-FRIENDLY MATERIAL**  
Good recyclability due to mono material

**ENHANCED HYGIENE**  
Suitable for the food industry

**DIRT-INSENSITIVE DESIGN**  
Less maintenance

**PERMANENT WASHABILITY**  
Extremely hard-wearing and hygienic

**COLOUR MATCHING**  
Design flexibility and consistency

**CHEMICAL-RESISTANT COMPONENTS**  
Particularly durable and resistant to cleaning

Load Capacity 35 - 200 KG

Wheel Diameter 38 - 400 mm

Compatible with...



ALPHA

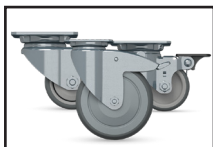

AGILA



LUMINA



COMPACTA

Scan the QR to view full information on the Basetech wheel



# Alpha

Industrial Castors



**USER-FRIENDLY CENTRAL LOCK**  
Simultaneous locking of more than one castor using a central activation level

**PRACTICAL SYSTEM SOLUTION**  
Practical system solution with all technical components for central locking

**SECURE STANCE**  
Total lock for simultaneously locking the wheel and swivel housing

**OPTIMISED STEERING ABILITY**  
Directional lock for improved stability when steering around bends as well as moving in a straight line for long distances

Typically used in...

INTRALOGISTICS

MACHINERY

RETAIL & TRADE

To view the full details on the Alpha family scan the QR



# Duratech

Polyamide Wheels



# Compacta

Equipment Castors



- HIGH-PRESSURE STABILITY**  
Non-deformable for enhanced running comfort
- ABRASION RESISTANT TREAD**  
Ensuring minimal maintenance
- QUIET RUNNING**  
Reduces noise significantly
- LOW-VIBRATION TRANSPORT**  
Protects transported goods
- RESISTANCE TO COLD**  
Practically durable
- IDEAL MANOEUVRABILITY**  
Smooth running and swivelling

Load Capacity 55 - 7500 KG

Wheel Diameter 50 - 400 mm

Compatible with...



Scan the QR to view full information on the Duratech wheel



**CERTIFIED QUALITY**  
Tested for compliance with European standards

**NON-HAZARDOUS MATERIALS**  
Complies with RoHS and REACH regulations. Does not contain polycyclic aromatic carbons or chromium (VI)

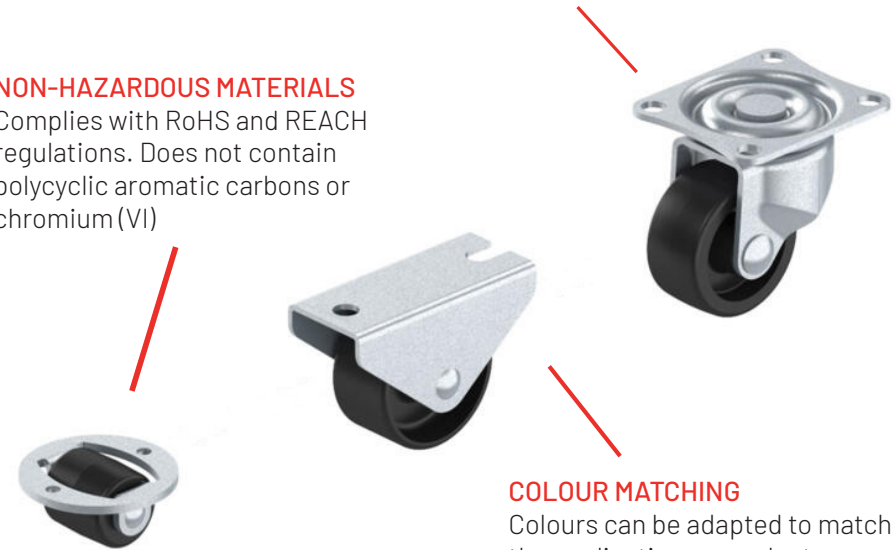

**COLOUR MATCHING**  
Colours can be adapted to match the application or product design

Typically used in...



To view the full details on the Compacta family scan the QR





# Elastech

Elastic Rubber Wheels

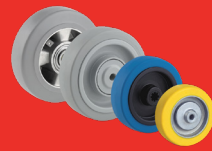

- LOW-VIBRATION TRANSPORT**  
Protects transported goods
- COMFORTABLE HANDLING**  
Easy to navigate around obstacles
- HEAT-RESISTANT**  
Protects transported goods
- PERMANENT WASHABILITY**  
Extremely hard-wearing and hygienic
- CERTIFIED CONDUCTIVITY**  
Safe for sensitive environments
- LOW-MAINTENANCE DESIGN**  
Reduced clogging due to thread guard

Load Capacity 80 - 8020 KG

Wheel Diameter 100 - 920 mm

Compatible with...

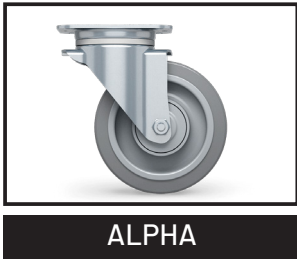

ALPHA

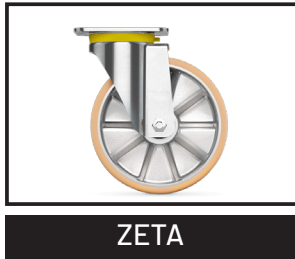

ZETA



KAPPA

Scan the QR to view full information on the Elastech wheel



# Kappa

Heavy-Duty Industrial Castors



- RELIABLE TRACTION**  
Traction optimised treads for secure grip on wet and slippery floors
- FLEXIBLE LOCK FUNCTION**  
Use of two independent actuation systems
- EASY STEERING**  
Axial groove ball bearing with dual purpose and tapered roller bearing for excellent swivelling properties under high loads

Typically used in...



To view the full details on the Kappa family scan the QR



# Maxtech

Injection-moulded Polyurethane Wheels

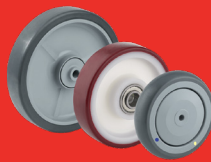

- CERTIFIED CONDUCTIVITY**  
To protect users and electronic devices
- LOW MAINTENANCE DESIGN**  
Reduced clogging due to the tread guard
- VARIABLE HARDNESS**  
Ideal material properties for every purpose
- ADAPTABLE DESIGN**  
Ability to accommodate application specific design
- PERMANENT WASHABILITY**  
Extremely hard-wearing and hygienic
- ABRASION RESISTANT TREAD**  
Low maintenance

Load Capacity 40 - 500 KG

Wheel Diameter 50 - 200 mm

Compatible with...



ALPHA



AGILA



ZETA



STYLEA

Scan the QR to view full information on the Maxtech wheel



# Linea

High-Functioning Castors



- EFFICIENT OPERATION**  
Central locking at the touch of a button
- SECURE LOCKING**  
Until the pedal or handle is activated by the user
- FASCINATING PICTURE PRINTS**  
Entire wheel caps printable with almost every theme

Typically used in...



To view the full details on the Linea family scan the QR



# Novatech

Casted Polyurethane Wheels

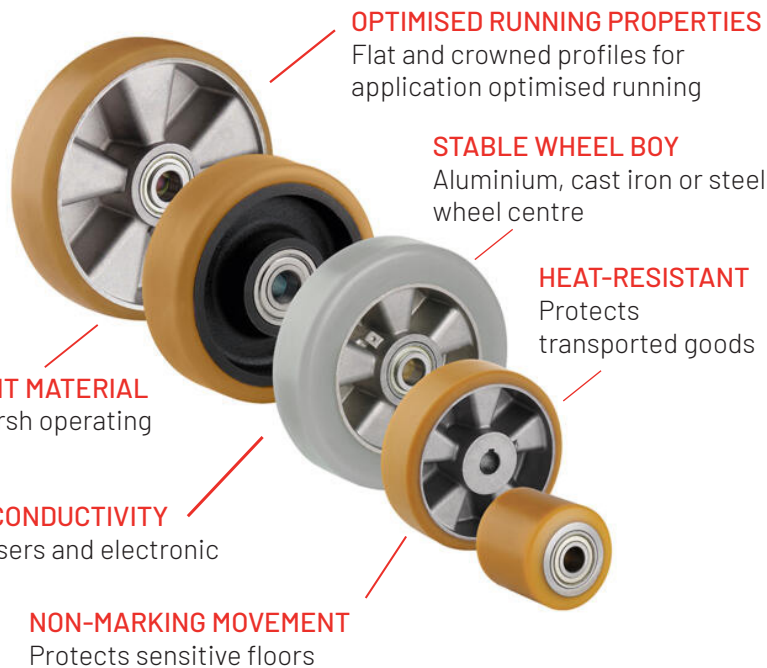

### OPTIMISED RUNNING PROPERTIES

Flat and crowned profiles for application optimised running

### STABLE WHEEL BOY

Aluminium, cast iron or steel wheel centre

### HEAT-RESISTANT

Protects transported goods

### CUT RESISTANT MATERIAL

Suitable for harsh operating conditions

### CERTIFIED CONDUCTIVITY

To protect users and electronic devices

### NON-MARKING MOVEMENT

Protects sensitive floors

Load Capacity 100 - 5300 KG

Wheel Diameter 35 - 500 mm

### Compatible with...

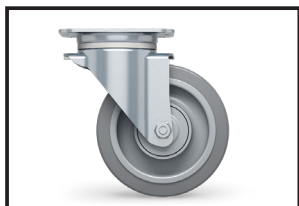

ALPHA

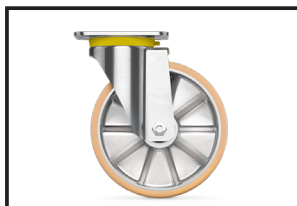

ZETA

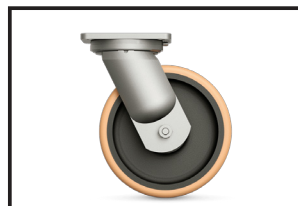

KAPPA

Scan the QR to view full information on the Novatech wheel



# Lumina

Furniture Castors

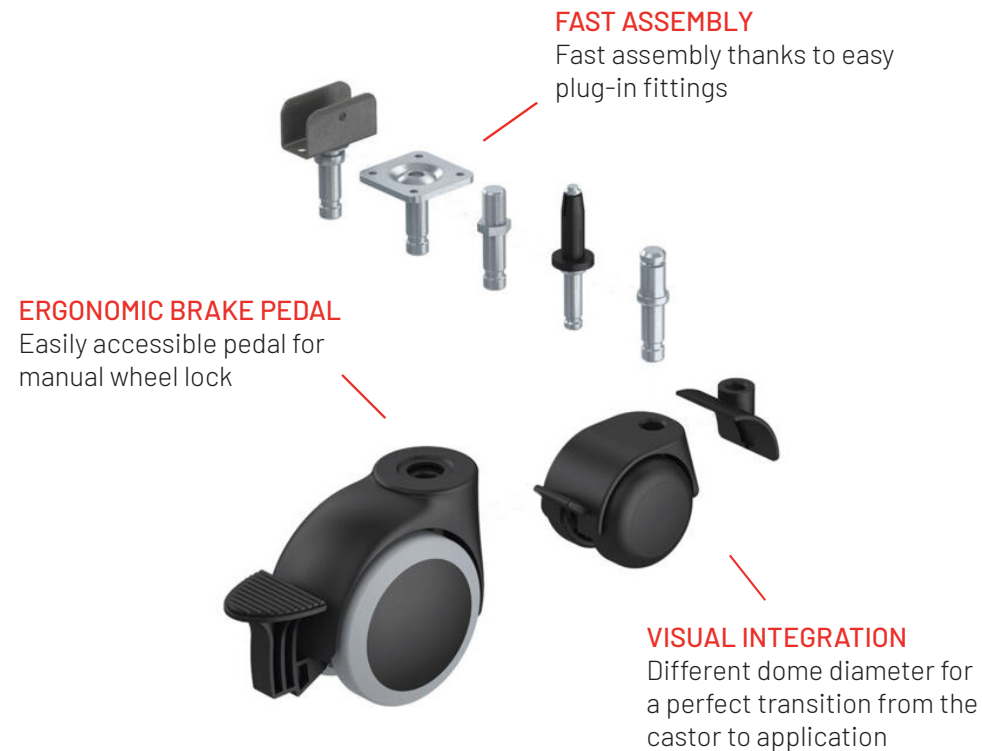

### FAST ASSEMBLY

Fast assembly thanks to easy plug-in fittings

### ERGONOMIC BRAKE PEDAL

Easily accessible pedal for manual wheel lock

### VISUAL INTEGRATION

Different dome diameter for a perfect transition from the castor to application

Typically used in...



To view the full details on the Lumina family scan the QR



# Puretech

Rubber Wheels

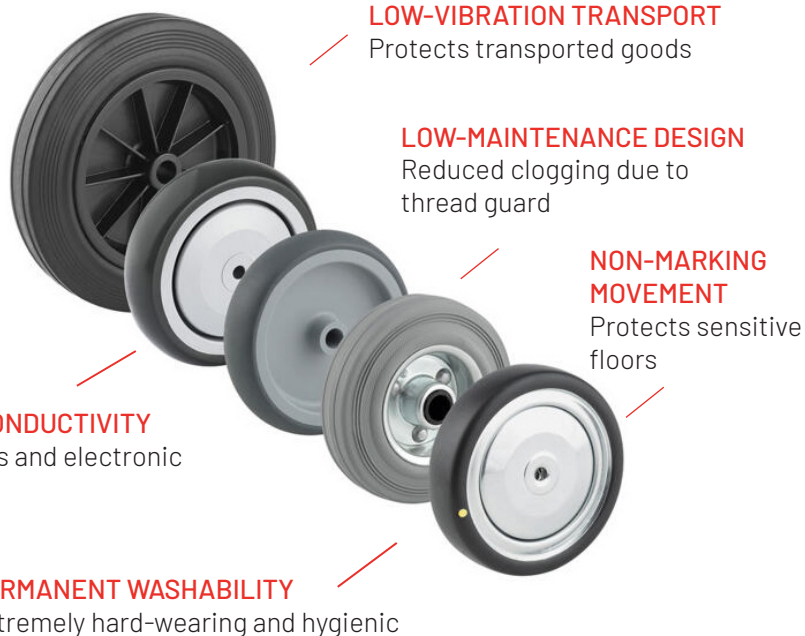

**LOW-VIBRATION TRANSPORT**  
Protects transported goods

**LOW-MAINTENANCE DESIGN**  
Reduced clogging due to thread guard

**NON-MARKING MOVEMENT**  
Protects sensitive floors

**CERTIFIED CONDUCTIVITY**  
Protects users and electronic devices

**PERMANENT WASHABILITY**  
Extremely hard-wearing and hygienic

Load Capacity 55 - 7500 KG

Wheel Diameter 50 - 400 mm

Compatible with...



Scan the QR to view full information on the Puretech wheel



# Stylea

For Timeless Designs

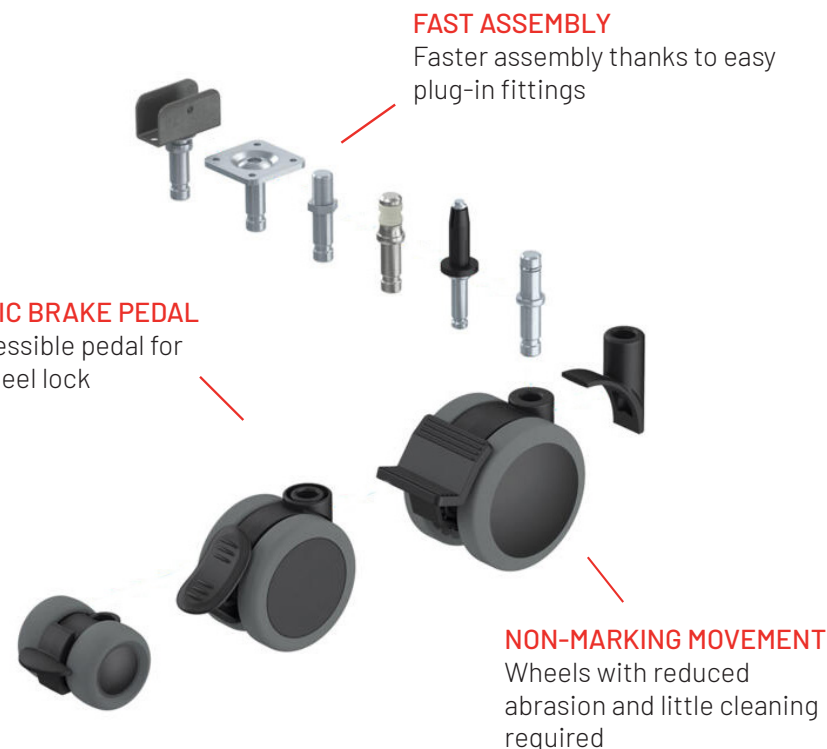

**FAST ASSEMBLY**  
Faster assembly thanks to easy plug-in fittings

**ERGONOMIC BRAKE PEDAL**  
Easily accessible pedal for manual wheel lock

**NON-MARKING MOVEMENT**  
Wheels with reduced abrasion and little cleaning required

Typically used in...



To view the full details on the Stylea family scan the QR





# Supratech

Thermoplastic Wheels

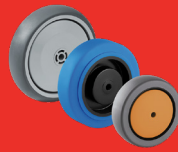

**CERTIFIED CONDUCTIVITY**

To protect users and electronic devices

**LOW-MAINTENANCE DESIGN**

Reduced clogging due to the tread guard

**COLOUR MATCHING**

Design flexibility and branding

**NON-MARKING MOVEMENT**

Protects sensitive floors

**PERMANENT WASHABILITY**

Extremely hard-wearing and hygienic

**QUIET RUNNING**

Significant noise reduction

Load Capacity 50 - 160 KG

Wheel Diameter 50 - 200 mm

**Compatible with...**



ALPHA



LINEA

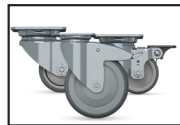

AGILA



LUMINA



STYLEA

Scan the QR to view full information on the Supratech wheel



# Zeta

Heavy-Duty Industrial Castors



**OPTIMISED DIRECTIONAL LOCK**

Directional lock can be adjusted to your requirements to 2 x 180°

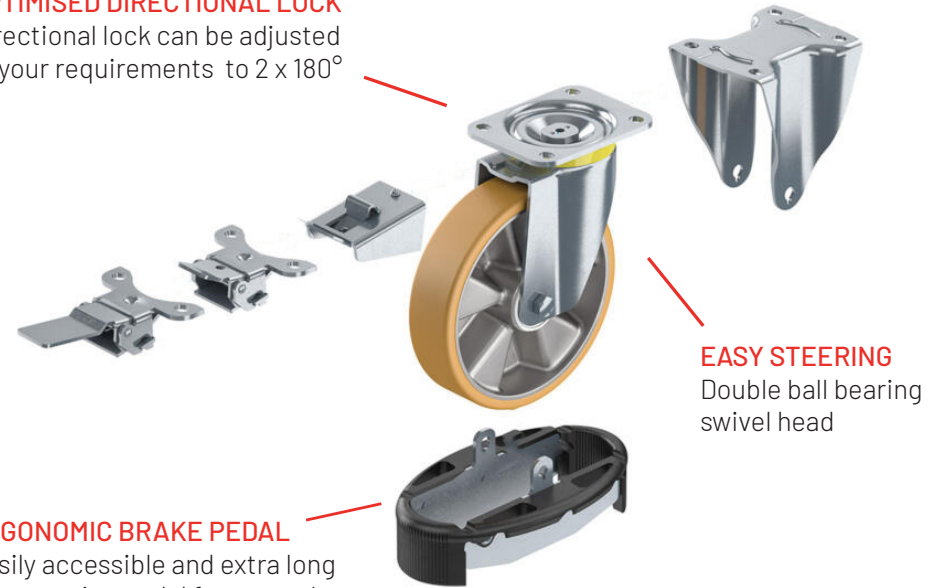

**EASY STEERING**

Double ball bearing swivel head

**ERGONOMIC BRAKE PEDAL**

Easily accessible and extra long XL operating pedal for manual directional lock

Typically used in...



To view the full details on the Zeta family scan the QR



# Castors & Wheels for all industries

Don't see your industry?  
Don't worry!

Scan the QR code or visit [www.jetpress.com](http://www.jetpress.com) to learn more about which castors are relevant for your industry



Automotive



Furniture



Machinery



Medical



Intralogistics



Retail & Trading



Stem Threads



## Automotive

Leading automotive manufacturers and suppliers are dependent on castors within application orientated storage solution with durability and speed being vital factors. These castors not only aim to meet these needs but to go one step further through user-friendliness, productivity and transport.



### Automotive Castor | Swivel | Plate | Zeta & Novatech



Load Capacity (kg)	Wheel Diameter (mm)	Overall Height (mm)	Hole Centre (mm)	Plate Size (mm)	Part Number
500	125	164	11	137 x 105	CTR236Z
800	160	200	11	137 x 105	CTR237Z
800	200	240	11	137 x 105	CTR238Z

### Automotive Castor | Braked | Swivel | Plate | Zeta & Novatech



Load Capacity (kg)	Wheel Diameter (mm)	Overall Height (mm)	Hole Centre (mm)	Plate Size (mm)	Part Number
500	125	164	11	137 x 105	CTR239Z
800	160	200	11	137 x 105	CTR240Z
800	200	240	11	137 x 105	CTR241Z

### Automotive Castor | Fixed | Plate | Zeta & Novatech



Load Capacity (kg)	Wheel Diameter (mm)	Overall Height (mm)	Hole Centre (mm)	Plate Size (mm)	Part Number
500	125	164	11	137 x 117	CTR242Z
800	160	200	11	137 x 117	CTR243Z
800	200	240	11	137 x 117	CTR244Z

## Furniture

Tente castors are a popular choice in the furniture industry due to their high-quality construction, durability and versatility. They are made from premium materials and designed to withstand heavy loads, making them ideal for furniture that needs to be moved frequently.



## Furniture

Our castors are available in a wide range of sizes and styles, making them suitable for a variety of furniture applications, including chairs, tables, cabinets and much more.



### Furniture Castor | Fixed | Plate | Compacta



Load Capacity (kg)	Wheel Diameter (mm)	Overall Height (mm)	Hole Centre (mm)	Plate Size (mm)	Part Number
25	14	17	4	30 x 17	CTR143
25	25	28	4.5	40 x 17	CTR144
30	30	34	5.5	45 x 20	CTR145Z
40	45	48.5	5.3	67 x 24	CTR146Z

### Furniture Castor | Low Height | Swivel | Stem | Stylea & Duratech



Load Capacity (kg)	Wheel Diameter (mm)	Overall Height (mm)	Hole Centre (mm)	Part Number
50	35	33	10	CTR265

### Furniture Castor | Swivel | Stem | Compacta



Load Capacity (kg)	Wheel Diameter (mm)	Overall Height (mm)	Hole Centre (mm)	Plate Size (mm)	Part Number
10	25	36	4.2	35 x 30	CTR147
20	32	43	4.2	38 x 32	CTR148Z
25	38	51	5.3	46 x 38	CTR149Z

### Furniture Castor | Low Height | Braked | Swivel | Stem | Stylea & Duratech



Load Capacity (kg)	Wheel Diameter (mm)	Overall Height (mm)	Hole Centre (mm)	Part Number
50	35	33	10	CTR266

### Furniture Castor | Swivel | Stem | Lumina & Basetech



Load Capacity (kg)	Wheel Diameter (mm)	Overall Height (mm)	Hole Centre (mm)	Part Number
40	50	56	8	CTR263Z
40	50	56	8	CTR264Z

### Furniture Castor | Swivel | Stem | Stylea & Supratech



Load Capacity (kg)	Wheel Diameter (mm)	Overall Height (mm)	Hole Centre (mm)	Part Number
50	65	68	10	CTR267

## Furniture

With a variety of mounting options available, installation is simple and easy to integrate effortlessly into furniture designs.



### Furniture Castor | Braked | Swivel | Stem | Stylea & Supratech



Load Capacity (kg)	Wheel Diameter (mm)	Overall Height (mm)	Hole Centre (mm)	Part Number
50	65	68	10	CTR268



## Machinery

Tente castors are commonly used in machinery to provide smooth and efficient movement; allowing heavy machinery to be easily maneuvered.



### Machinery & Workshop Castor | Swivel | Plate | Alpha & Duratech



Load Capacity (kg)	Wheel Diameter (mm)	Overall Height (mm)	Hole Centre (mm)	Plate Size (mm)	Part Number
200	80	108	9	105 x 80	CTR202Z1
200	100	128	9	105 x 80	CTR203
250	125	155	9	105 x 80	CTR204
350	160	200	11	137 x 105	CTR205Z
350	200	240	11	137 x 105	CTR206Z

### Machinery & Workshop Castor | Braked | Swivel | Plate | Alpha & Duratech



Load Capacity (kg)	Wheel Diameter (mm)	Overall Height (mm)	Hole Centre (mm)	Plate Size (mm)	Part Number
200	80	108	9	105 x 80	CTR207Z
200	100	128	9	105 x 80	CTR208
250	125	155	9	105 x 80	CTR209
350	160	200	11	137 x 105	CTR210Z
350	200	240	11	137 x 105	CTR211Z

### Machinery & Workshop Castor | Fixed | Plate | Alpha & Duratech



Load Capacity (kg)	Wheel Diameter (mm)	Overall Height (mm)	Hole Centre (mm)	Plate Size (mm)	Part Number
200	80	108	9	103 x 85	CTR212Z
200	100	128	9	103 x 85	CTR213
250	125	155	9	103 x 85	CTR214
350	160	200	11	137 x 115	CTR215Z
350	200	240	11	140 x 115	CTR216Z



## Machinery

These castors are made with high-quality materials, offering excellent traction even in harsh working conditions, helping to provide excellent durability and high load-bearing capacity.



### Machinery & Workshop Castor | Swivel | Plate | Alpha & Maxtech



Load Capacity (kg)	Wheel Diameter (mm)	Overall Height (mm)	Hole Centre (mm)	Plate Size (mm)	Part Number
150	80	108	9	105 x 80	CTR217Z

## Machinery

With their ability to spin 360° these castors provide excellent maneuverability and can be used to move heavy machinery with ease, making them a popular choice among manufacturers.

### Machinery & Workshop Castor | Swivel | Plate | Kappa & Novatech



Load Capacity (kg)	Wheel Diameter (mm)	Overall Height (mm)	Hole Centre (mm)	Plate Size (mm)	Part Number
550	125	170	11	135 x 110	CTR245Z
750	160	205	11	135 x 110	CTR246Z
1000	200	245	11	135 x 110	CTR247Z

### Machinery & Workshop Castor | Braked | Swivel | Plate | Alpha & Maxtech



Load Capacity (kg)	Wheel Diameter (mm)	Overall Height (mm)	Hole Centre (mm)	Plate Size (mm)	Part Number
150	80	108	9	105 x 80	CTR218Z

### Machinery & Workshop Castor | Braked | Swivel | Plate | Kappa & Novatech



Load Capacity (kg)	Wheel Diameter (mm)	Overall Height (mm)	Hole Centre (mm)	Plate Size (mm)	Part Number
550	125	170	11	135 x 110	CTR248Z
750	160	205	11	135 x 110	CTR249Z
1000	200	245	11	135 x 110	CTR250Z

### Machinery & Workshop Castor | Fixed | Alpha & Maxtech



Load Capacity (kg)	Wheel Diameter (mm)	Overall Height (mm)	Hole Centre (mm)	Plate Size (mm)	Part Number
150	80	108	9	103 x 85	CTR219Z

### Machinery & Workshop Castor | Fixed | Plate | Kappa & Novatech



Load Capacity (kg)	Wheel Diameter (mm)	Overall Height (mm)	Hole Centre (mm)	Plate Size (mm)	Part Number
550	125	170	11	135 x 110	CTR251Z
750	160	205	11	135 x 110	CTR252Z
1000	200	245	11	135 x 110	CTR253Z

## Medical

Tente castors are made from high-quality materials and are designed to withstand the rigorous demands of the medical environment including frequent cleaning and sterilisation.

## Medical

Tente castors can handle heavy loads and offer excellent mobility and stability, which are crucial for patient safety and comfort. They are also designed to provide silent operation, which is critical in healthcare settings where noise levels must be kept to a minimum.



### Medical Castor | Swivel | Stem | Twin Wheel | Linea & Maxtech



Load Capacity (kg)	Wheel Diameter (mm)	Overall Height (mm)	Hole Centre (mm)	Part Number
100	50	50.5	10	CTR255

### Medical Castor | Braked | Swivel | Stem | Twin Wheel | RAL 9002 | Linea & Maxtech



Load Capacity (kg)	Wheel Diameter (mm)	Overall Height (mm)	Hole Centre (mm)	Part Number
90	65	68	10	CTR260Z
100	75	75.5	10	CTR261Z
100	100	100	11	CTR262Z

### Medical Castor | Braked | Swivel | Stem | Twin Wheel | Linea & Maxtech



Load Capacity (kg)	Wheel Diameter (mm)	Overall Height (mm)	Hole Centre (mm)	Part Number
200	80	108	9	CTR256



### Medical Castor | Swivel | Stem | Twin Wheel | RAL 9002 | Linea & Maxtech



Load Capacity (kg)	Wheel Diameter (mm)	Overall Height (mm)	Hole Centre (mm)	Part Number
90	65	68	10	CTR257Z
100	75	75.5	10	CTR258Z
100	100	100	11	CTR259Z

## Intralogistics

Our castors are designed to handle heavy loads and are made from high-quality materials that can withstand the rigours of industrial environments.



## Intralogistics

With a wide range of styles and sizes including swivel and fixed options, these castors are designed to integrate seamlessly with different types of equipment such as trolleys, pallet trucks and conveyor belts.



### Intralogistics Castor | Swivel | Plate | Alpha & Elastech



Load Capacity (kg)	Wheel Diameter (mm)	Overall Height (mm)	Hole Centre (mm)	Plate Size (mm)	Part Number
160	100	128	9	105 x 80	CTR184
250	125	155	9	105 x 80	CTR185

### Grey Intralogistics Castor | Swivel | Plate | Alpha & Elastech



Load Capacity (kg)	Wheel Diameter (mm)	Overall Height (mm)	Hole Centre (mm)	Plate Size (mm)	Part Number
160	100	128	9	105 x 80	CTR190Z
250	125	155	9	105 x 80	CTR191Z
300	160	200	11	137 x 105	CTR192Z
400	200	240	11	137 x 105	CTR193Z

### Intralogistics Castor | Braked | Swivel | Plate | Alpha & Elastech



Load Capacity (kg)	Wheel Diameter (mm)	Overall Height (mm)	Hole Centre (mm)	Plate Size (mm)	Part Number
160	100	128	9	105 x 80	CTR186
250	125	155	9	105 x 80	CTR187

### Grey Intralogistics Castor | Braked | Swivel | Plate | Alpha & Elastech



Load Capacity (kg)	Wheel Diameter (mm)	Overall Height (mm)	Hole Centre (mm)	Plate Size (mm)	Part Number
160	100	128	9	105 x 80	CTR194Z
250	125	155	9	105 x 80	CTR195Z
300	160	200	11	137 x 105	CTR196Z
400	200	240	11	137 x 105	CTR197Z

### Intralogistics Castor | Fixed | Plate | Alpha & Elastech



Load Capacity (kg)	Wheel Diameter (mm)	Overall Height (mm)	Hole Centre (mm)	Plate Size (mm)	Part Number
160	100	128	9	103 x 85	CTR188
250	125	155	9	103 x 85	CTR189

### Grey Intralogistics Castor | Fixed | Plate | Alpha & Elastech



Load Capacity (kg)	Wheel Diameter (mm)	Overall Height (mm)	Hole Centre (mm)	Plate Size (mm)	Part Number
160	100	128	9	103 x 85	CTR198Z
250	125	155	9	103 x 85	CTR199Z
300	160	200	11	137 x 115	CTR200Z
400	200	240	11	140 x 115	CTR201Z

## Intralogistics

These castors are also equipped with advanced features such as noise reduction, directional locking and shock absorption, making these castors an efficient and reliable choice for business.



## Intralogistics

Overall the use of our castors in intralogistics significantly improves productivity, reduces the risk of workplace injuries and ultimately enhances the efficiency of a facility's operations.



### Intralogistics Castor | Swivel | Plate | Alpha & Maxtech



Load Capacity (kg)	Wheel Diameter (mm)	Overall Height (mm)	Hole Centre (mm)	Plate Size (mm)	Part Number
150	100	128	9	105 x 80	CTR220
200	125	155	9	105 x 80	CTR221
350	160	200	11	137 x 105	CTR222Z
350	200	240	11	137 x 105	CTR223Z

### Intralogistics Castor | Swivel | Stem | Alpha & Maxtech



Load Capacity (kg)	Wheel Diameter (mm)	Overall Height (mm)	Hole Centre (mm)	Part Number
150	100	128	13	CTR232Z
150	125	155	13	CTR233Z

### Intralogistics Castor | Braked | Swivel | Plate | Alpha & Maxtech



Load Capacity (kg)	Wheel Diameter (mm)	Overall Height (mm)	Hole Centre (mm)	Plate Size (mm)	Part Number
150	100	128	9	105 x 80	CTR224
200	125	155	9	105 x 80	CTR225
350	160	200	11	137 x 105	CTR226Z
350	200	240	11	137 x 105	CTR227Z

### Intralogistics Castor | Braked | Swivel | Stem | Alpha & Elastech



Load Capacity (kg)	Wheel Diameter (mm)	Overall Height (mm)	Hole Centre (mm)	Part Number
150	100	128	13	CTR234Z
150	125	155	13	CTR235Z

### Intralogistics Castor | Fixed | Plate | Alpha & Maxtech



Load Capacity (kg)	Wheel Diameter (mm)	Overall Height (mm)	Hole Centre (mm)	Plate Size (mm)	Part Number
150	100	128	9	103 x 85	CTR228
200	125	155	9	103 x 85	CTR229
350	160	200	11	137 x 115	CTR230Z
350	200	240	11	140 x 115	CTR231Z





## Trading & Retail

Our castors have become an essential component of the trade and retail industry, offering a range of benefits that improve productivity, enhance the customer experience and reduce the risk of workplace injuries.



## Trading & Retail

These castors are designed to provide optimal mobility and stability, making them a versatile solution for a wide range of applications.



### Retail & Trade Castor | Swivel | Plate | Alpha & Puretech



Load Capacity (kg)	Wheel Diameter (mm)	Overall Height (mm)	Hole Centre (mm)	Plate Size (mm)	Part Number
70	100	128	9	105 x 85	CTR171Z
100	125	155	9	105 x 85	CTR172Z
135	160	200	11	137 x 105	CTR173
205	200	240	11	137 x 105	CTR174

### Retail & Trade Castor | Total Lock | Swivel | Plate | Lead Brake | Alpha & Puretech



Load Capacity (kg)	Wheel Diameter (mm)	Overall Height (mm)	Hole Centre (mm)	Plate Size (mm)	Part Number
205	200	240	11	137 x 105	CTR183

### Retail & Trade Castor | Total Lock | Swivel | Plate | Alpha & Puretech



Load Capacity (kg)	Wheel Diameter (mm)	Overall Height (mm)	Hole Centre (mm)	Plate Size (mm)	Part Number
70	100	128	9	105 x 85	CTR175Z
100	125	155	9	105 x 85	CTR176Z
135	160	200	11	137 x 105	CTR177
205	200	240	11	137 x 105	CTR178Z

### Retail & Trade Wheel | Bearing Wheel | Basetech Foam



Load Capacity (kg)	Wheel Diameter (mm)	Overall Height (mm)	Part Number
75	260	260	CTR254

### Retail & Trade Castor | Fixed | Plate | Alpha & Puretech



Load Capacity (kg)	Wheel Diameter (mm)	Overall Height (mm)	Hole Centre (mm)	Plate Size (mm)	Part Number
70	100	128	9	103 x 85	CTR179Z
100	125	155	9	103 x 85	CTR180Z
135	160	200	11	137 x 115	CTR181
205	200	240	11	140 x 115	CTR182

### Retail & Trade Castor | Swivel | Stem | Agila & Maxtech



Load Capacity (kg)	Wheel Diameter (mm)	Overall Height (mm)	Hole Centre (mm)	Part Number
40	50	70	11	CTR150
60	75	100	11	CTR151

## Trading & Retail

One of the primary uses is transporting items that can be challenging to move, with our castors specifically designed to handle heavy loads, allowing easy transportation, reducing manual labour and ensuring products are readily available.

## Trading & Retail

Our castors provide excellent manoeuvrability, allowing for ease of navigation and with the various sizes and styles our castors offer customisation that can be based upon specific needs.



Retail & Trade Castor | Swivel | Plate | Polypropylene | Agila & Basetech



Load Capacity (kg)	Wheel Diameter (mm)	Overall Height (mm)	Hole Centre (mm)	Plate Size (mm)	Part Number
40	50	70	6.3	60 x 60	CTR154Z

Retail & Trade Castor | Braked | Swivel | Plate | Agila & Maxtech



Load Capacity (kg)	Wheel Diameter (mm)	Overall Height (mm)	Hole Centre (mm)	Plate Size (mm)	Part Number
40	50	70	6.3	60 x 60	CTR157

Retail & Trade Castor | Braked | Swivel | Stem | Polypropylene | Agila & Basetech



Load Capacity (kg)	Wheel Diameter (mm)	Overall Height (mm)	Hole Centre (mm)	Part Number
40	50	70	11	CTR155Z

Retail & Trade Castor | Braked | Swivel | Stem | Polypropylene | Agila & Basetech



Load Capacity (kg)	Wheel Diameter (mm)	Overall Height (mm)	Hole Centre (mm)	Part Number
40	50	70	6.3	CTR158Z

Retail & Trade Castor | Braked | Swivel | Stem | Agila & Maxtech



Load Capacity (kg)	Wheel Diameter (mm)	Overall Height (mm)	Hole Centre (mm)	Part Number
40	50	70	11	CTR156

Retail & Trade Castor | Braked | Swivel | Plate | Polypropylene | Agila & Basetech



Load Capacity (kg)	Wheel Diameter (mm)	Overall Height (mm)	Hole Centre (mm)	Plate Size (mm)	Part Number
40	50	70	6.3	60 x 60	CTR159Z

## Trading & Retail

Whether it is for restocking shelves, moving merchandise around the sales floor or setting up exhibits, our castors are a reliable and versatile solution that can help businesses streamline their operations and increase their bottom line.



## Trading & Retail

Our castors ability to handle heavy items, provide excellent manoeuvrability and reduce the risk of workplace injuries make them a valuable asset for any retail or trade operation.



### Retail & Trade Castor | Total Lock | Swivel | Stem | Alpha & Maxtech



Load Capacity (kg)	Wheel Diameter (mm)	Overall Height (mm)	Hole Centre (mm)	Part Number
60	75	100	11	CTR160

### Retail & Trade Castor | Swivel | Stem | Agila & Supratech



Load Capacity (kg)	Wheel Diameter (mm)	Overall Height (mm)	Hole Centre (mm)	Part Number
80	100	135	13	CTR163

### Retail & Trade Castor | Total Lock | Swivel | Plate | Alpha & Maxtech



Load Capacity (kg)	Wheel Diameter (mm)	Overall Height (mm)	Hole Centre (mm)	Plate Size	Part Number
60	75	100	6.3	60 x 60	CTR161

### Retail & Trade Castor | Swivel | Plate | Agila & Supratech



Load Capacity (kg)	Wheel Diameter (mm)	Overall Height (mm)	Hole Centre (mm)	Plate Size	Part Number
80	100	135	8.5	77 x 67	CTR164
100	125	160	8.5	77 x 67	CTR165Z

### Retail & Trade Castor | Swivel | Bolt | Agila & Maxtech



Load Capacity (kg)	Wheel Diameter (mm)	Overall Height (mm)	Part Number
100	35	58	CTR162Z

### Retail & Trade Castor | Swivel | Agila & Supratech



Load Capacity (kg)	Wheel Diameter (mm)	Overall Height (mm)	Hole Centre (mm)	Part Number
100	125	160	13	CTR166Z

## Trading & Retail

Our castors contribute to a safer work environment due to the mobility and the stability provided can reduce the risk of injuries that can occur. Additionally the ability to move with minimal force promotes a healthy and safe work environment impacting the overall well-being of staff.



## Threaded Stems

Threaded stems are a popular mounting system in castors. The threaded bolt protrudes from the bottom of the castor, making it easy to install and remove from a socket or hole. They come in different sizes to fit a range of castors, providing reliability in industries like medical and automotive.



### Retail & Trade Castor | Total Lock | Swivel | Stem | Agila & Supratech



Load Capacity (kg)	Wheel Diameter (mm)	Overall Height (mm)	Hole Centre (mm)	Part Number
80	100	135	13	CTR167

### Threaded Stem | Hexagon Neck



Load Capacity (kg)	Overall Height (mm)	Thread Size	Thread Length (mm)	Depth of Bottom Stem	Part Number
100	6	M10	15	11	CTR269Z
80	6	M10	15	10	CTR270
50	6	M8	15	10	CTR271
40	6	M10	15	8	CTR272Z
40	6	M8	15	8	CTR273Z

### Retail & Trade Castor | Total Lock | Swivel | Plate | Agila & Supratech



Load Capacity (kg)	Wheel Diameter (mm)	Overall Height (mm)	Hole Centre (mm)	Plate Size (mm)	Part Number
80	100	135	8.5	77 x 67	CTR168
100	125	160	8.5	77 x 67	CTR169Z

### Threaded Stem | Plate Fitting



Load Capacity (kg)	Overall Height (mm)	Depth of Bottom Stem	Plate Size (mm)	Hole Centre (mm)	Part Number
40	10	8	38 x 38	5	CTR274
60	-	10	38 x 38	5	CTR275Z
60	-	10	42 x 42	5	CTR276
100	12	11	65 x 65	5	CTR277

### Retail & Trade Castor | Braked | Swivel | Agila & Supratech



Load Capacity (kg)	Wheel Diameter (mm)	Overall Height (mm)	Hole Centre (mm)	Part Number
100	125	160	13	CTR170Z

### Threaded Stem | Circlip



Load Capacity (kg)	Overall Height (mm)	Hole Centre (mm)	Part Number
60	4.5	-	CTR278Z

### Don't see the correct stem?

Don't worry if you can't find the right stem for your product. Please get in touch so we can help you find the right stem!



## Threaded Stems

The following is a guide on how to fit a threaded stem in your castor, highlighting the importance of selecting the correct size and type of stem and simple instructions on how to replace your old stem.

# Replacing a threaded stem

Over time threaded stems can become damaged or worn and will need replacing. Replacing a threaded stem in a Tente castor is a straightforward process that can be completed in minutes.

First, the correct size and type of threaded stem must be selected. Tente castors are available in a range of sizes and configurations so it is important you select the correct stem beforehand.

Once the correct stem has been selected, the old stem must be removed from the castor. This is achieved by unscrewing the stem from the mounting socket or hole. Pliers or a wrench may be required.

Once removed the new stem can then be inserted into the mounting socket or hole. Ensure that the stem is level and properly seated in the sock and then tighten with pliers or a wrench. Be careful to avoid over-tightening.

The castor should then be tested for stability and mobility. Give the equipment or furniture a gentle push to see if it moves smoothly. If the castor is not functioning correctly adjust the stem and if the problem persists double-check that the correct size and type of stem have been installed.

By following these simple steps, you can replace a threaded stem in a Tente castor and ensure that your equipment or furniture is safe and mobile.

